



ASIAN LE MANS SERIES COMMITTEE



TO: Teams Manufacturers
CATEGORY: LMP2 LMP3 GT3

DECISION N°: Asian_20252026_D03_GT3_Technical_information-**amended v2**

DATE: 01/12/2025 **FROM:** The Asian Le Mans Series Committee

SUBJECT: Technical information for GT3 category

APPLICABLE REGULATION

2025-2026 Asian Le Mans Series Sporting Regulations

DECISION

REAR WING ANGLE MEASUREMENT

Where a chassis reference plane is available inside the cockpit of the car the top surface of the plane shall remain unobstructed at all times to allow scrutineers to zero an inclinometer when carrying out rear wing angle measurements. The clearance volume above the plane shall be a minimum of 220mm long x 60mm wide x 65mm high.

ENGINE RESTRICTOR SIZES

To accommodate the BOP process requirements each Competitor/Manufacturer shall ensure that the following size engine restrictors for their cars are available at all events:

	Restrictor diameter list (mm)						
Corvette Chevrolet	43,5 45	44 46	44,5 48	45 50	46-52	47	48
Mercedes	33	34	34.5	35	36		
Porsche	36	37.5	38	39.5	40	41.5	

FUEL EQUIVALENCE

Each Competitor must test and find the restrictor diameter (with a maximum of 38.1 mm) for the combination car/pit system to achieve, for a complete refuelling volume** minimum 40 seconds.

**complete refuelling volume: fuel tank volume as run by the competitor in race conditions, that should also fulfil the maximum onboard fuel volume.

This should be achieved with the mandatory 2025-2026 Asian Le Mans Series fuel specification at ambient conditions at each Competition.

If the refueling time is found faster than the time above, it will be reported to Stewards (penalties to be clearly set before the start of the season).

For the purpose of the test of refueling time, the conditions will be:

- The car's fuel tank will be emptied with fuel bowser, leaving the rest of the fuel system charged.
- The fuel filling will be done with the autonomous tank completely full and the refuelling system as used by the competitor in race conditions.
- The car will be resting on its tyres on the ground.

Any decision taken by the Asian Le Mans Series Committee is not subject to appeal.



ASIAN LE MANS SERIES COMMITTEE



-The fuel tank will be considered full as soon as fuel comes out of the vent line. The filling step will be repeated twice.

Competitors are responsible of requesting the autonomous tank dead-man valve stop (if adjustable) to be sealed by ACO technical delegates no later than four hours before the start of the race.

On the complete opening range of the handle (from close stop to open stop), the valve inner opening may only reach its maximum diameter at the open stop. Control will be made with a calibrated ball that can never pass through the valve except if the full diameter is reached at open stop.

CAR HOMOLOGATION - Clarification

In article 6.1, “Homologated FIA GT3 cars” means cars and evolutions that were homologated on **or before** 2025 December 1st.

If a Competitor wishes to enter reliability evolution that **was will** homologated by **the FIA** after this date, **it they** must submit a request to the Asian Le Mans Series Committee. **The Committee shall consider such applications and where approved, shall specify in their response a date/event from when the evolution may be used.**

Cars that have been subject to a homologation update on or before 1st December 2025 and it is known prior to the first **Competition event** of the season that this update will become mandated by the FIA during the 2025-2026 ALMS season, shall be compliant with the mandated homologation version for all **Competitions events**.

ELECTRONIC EQUIPMENT

The use of Marelli Telemetry System is mandatory for 2025/2026 Asian Le Mans Series season.

The Telemetry System designed by Marelli is a “modular” system in which, on board the vehicle, the logging functionalities have been separated from the wireless functions.

The system is designed to log the data input from the mandatory sensors, some of which are directly connected to the logger. ~~The data is then stored on the systems’ USB flashdrive and must be uploaded each time a car enters the pitlane.~~

At the Technical delegate request, Competitors will be required to bring the usb stick for the following pit stop.

Competitor should come to pick up USB flashdrive to the technical delegate office prior to the pitstop to be able to change the usb key in the following pit stop

The integrated smart antenna also provides accurate live data transmitted via LTE. This allows the technical team to monitor mandatory sensor values while the car is running on track and review racing incidents and infringements with a minimum delay.

Furthermore, it connects the vehicle to race control, sending the GPS-position of the car to locate it on track and receiving flag signals to show on the marshalling display onboard the vehicle.

~~Teams~~ Competitors are requested to contact their car supplier in order to obtain their specific supports and looms for the installation of the Marelli system.

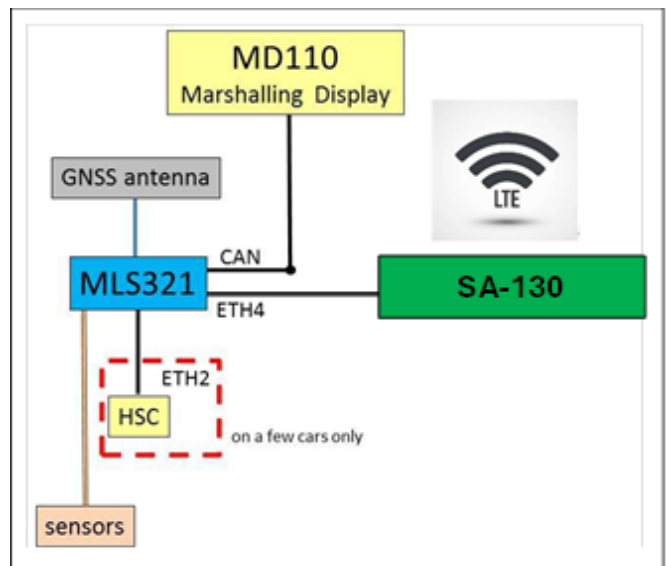



ASIAN LE MANS SERIES COMMITTEE



ELECTRONIC INFORMATION

Team CAN channels and FIA/ACO sensor signal must be correct at any time

BOOST CONTROL STRATEGY



LED Boost control strategy
V10 GT3

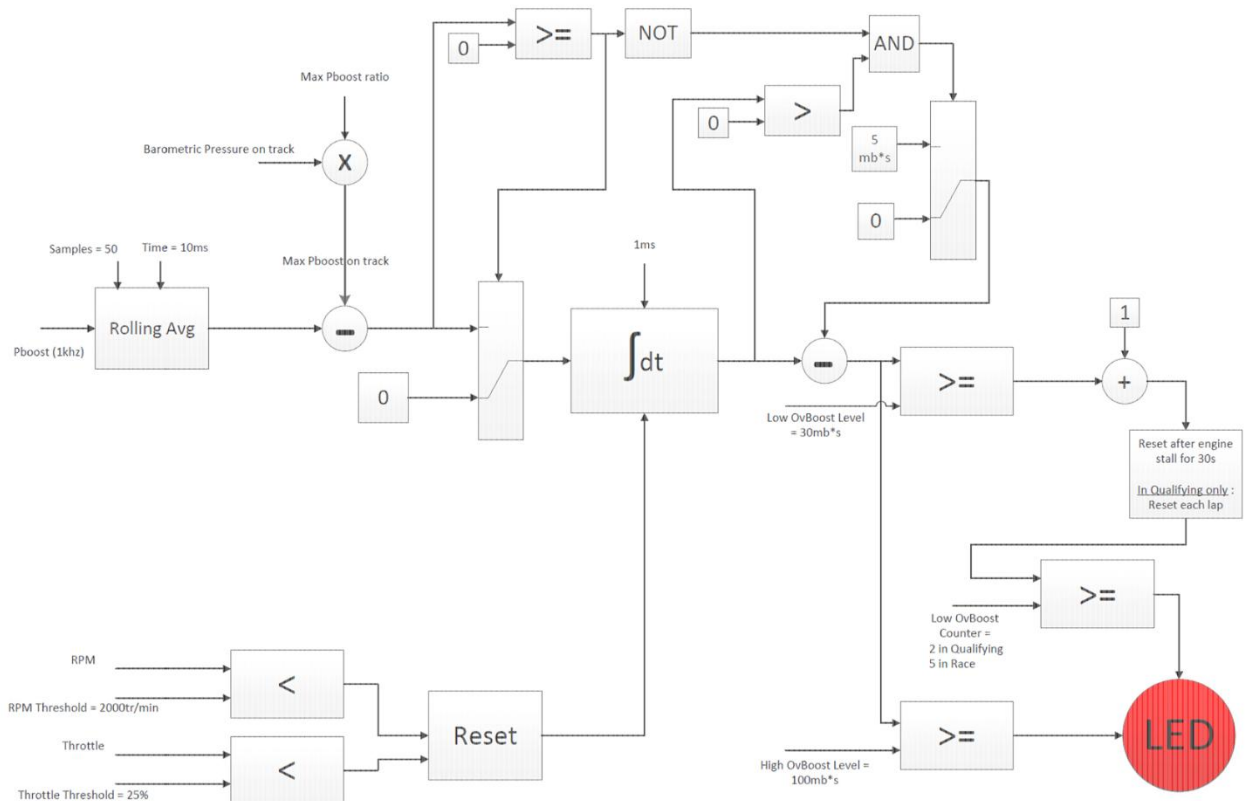

CHILLER UNIT

If you intend to install in your cockpit a chiller unit for ALMS events, and if this option/installation is not part of your car homologation form, please complete "chiller unit installation form", available in the last electronic package folder V1.1. This document must be sent to ACO for approval two weeks before the event.

Any installation must be mounted with fixation capable of accepting a 25 g deceleration.

No modification (including extra fixing holes,..) of a homologated chassis is permitted without the manufacturer approval and homologation document update.



ASIAN LE MANS SERIES COMMITTEE



PERIOD OF VALIDITY/APPLICATION OF THE DECISION

This decision comes into effect:

- with immediate application**
- from:

And is applicable:

- until further notice**
- for the mentioned event(s) only